

### Mounting of the kit on the valve (Fig 1 & Fig 2)

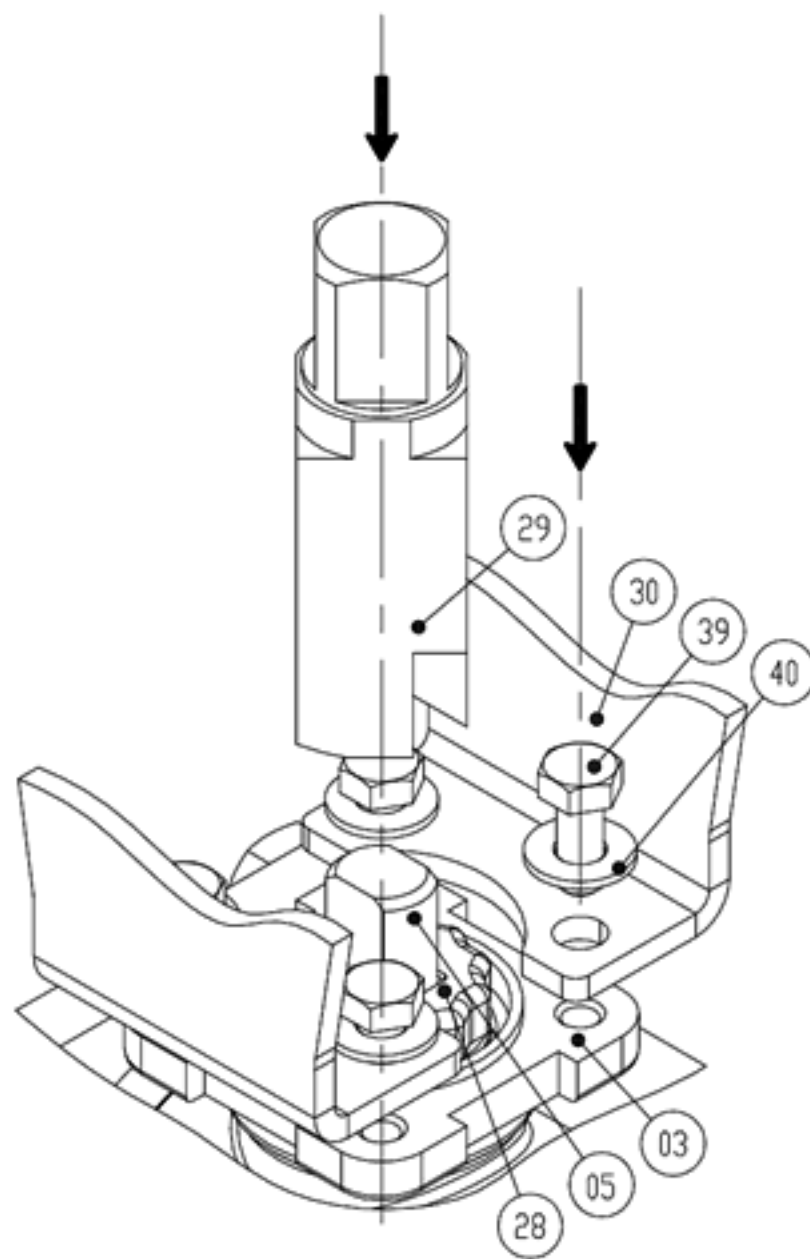

**Fig 1**

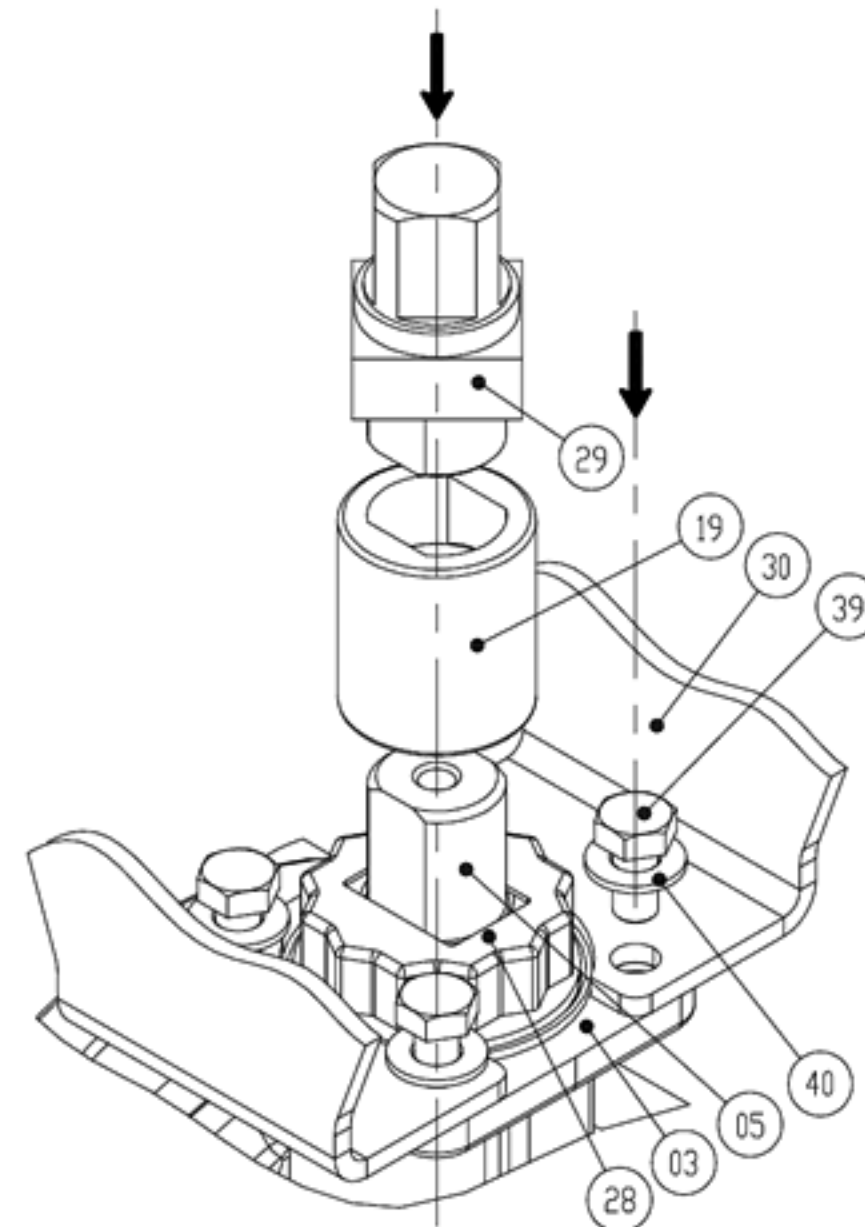

**Fig 2**

1. Position the kit (30) on Valve ISO top flange (03)
2. Check that nut stop (28) is mounted
3. Position the 4 washers (40) and the 4 screws (39) and tighten them all
4. Body DN 10 to 50: position coupling part (29) on the valve stem (05)
5. DN 65 to 200: position lever (19) on the valve stem (05) and insert coupling part (29) into the stem adaptor

### Mounting of the actuator on the kit (Fig 3)

#### Spring return actuator (SE)

Actuator is delivered in closed position when Failure Close and in Open position when Failure Open. When Failure close, it is necessary to close the valve either with lever or any appropriate tool by turning a 1/4 turn the valve stem (29). In case of Failure Open, make sure the valve is in the open position.

1. Insert actuator (31) onto the coupling part
2. Position the washers (33) and the screws (32)
3. Check actuator position (perpendicular to the valve)
4. Screw and tighten

#### Double Acting actuator (DE)

Double acting actuator is supplied in closed position. Visual indicator (41) is perpendicular to the actuator body (31).

1. Position the actuator (31) in the open position
2. Check that valve is in the open position
3. Insert actuator (31) onto coupling part (29)
4. Position the washers (33) and screws (32)
5. Check actuator position (must be perpendicular to the valve)
6. Screw and tighten

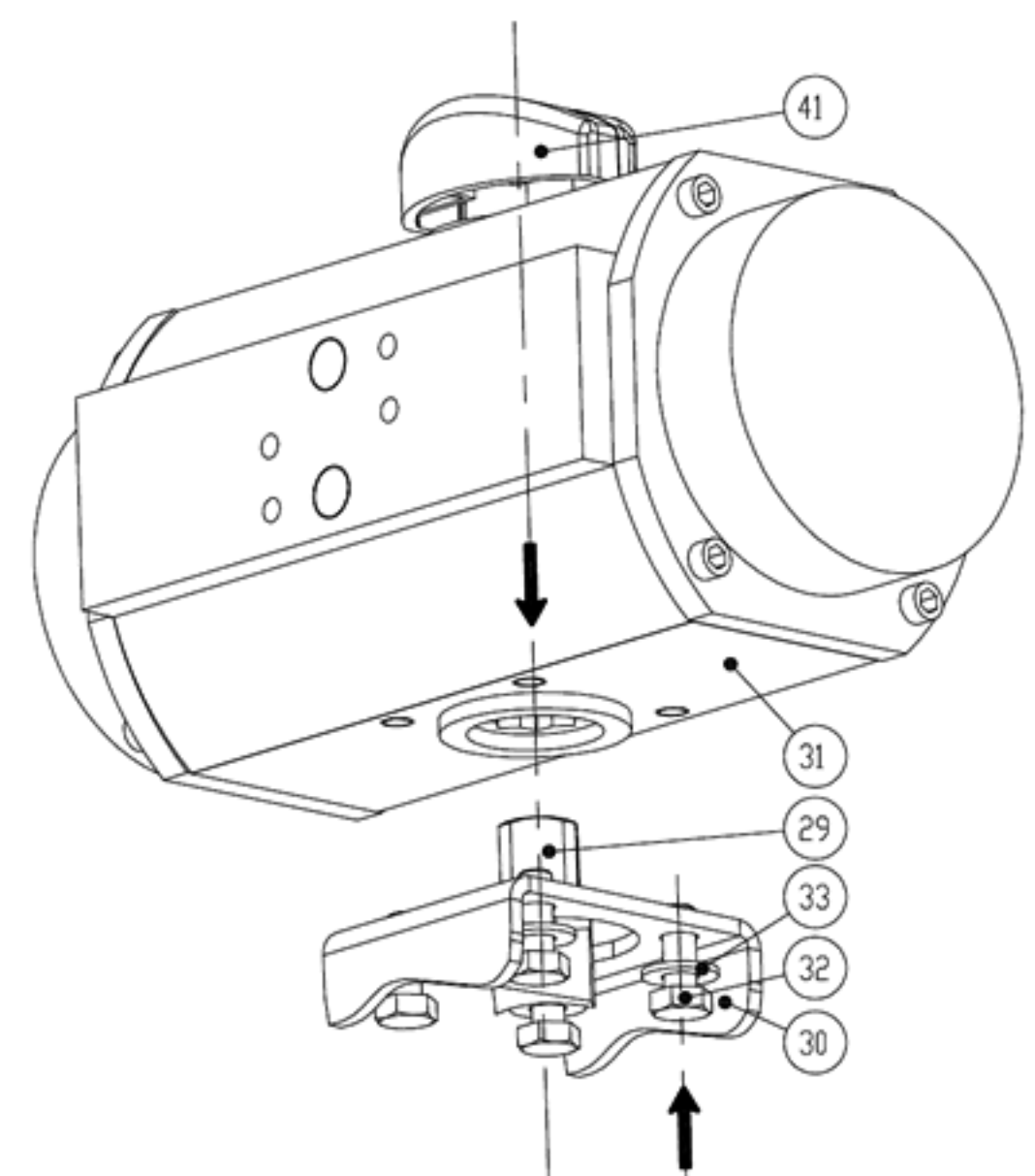
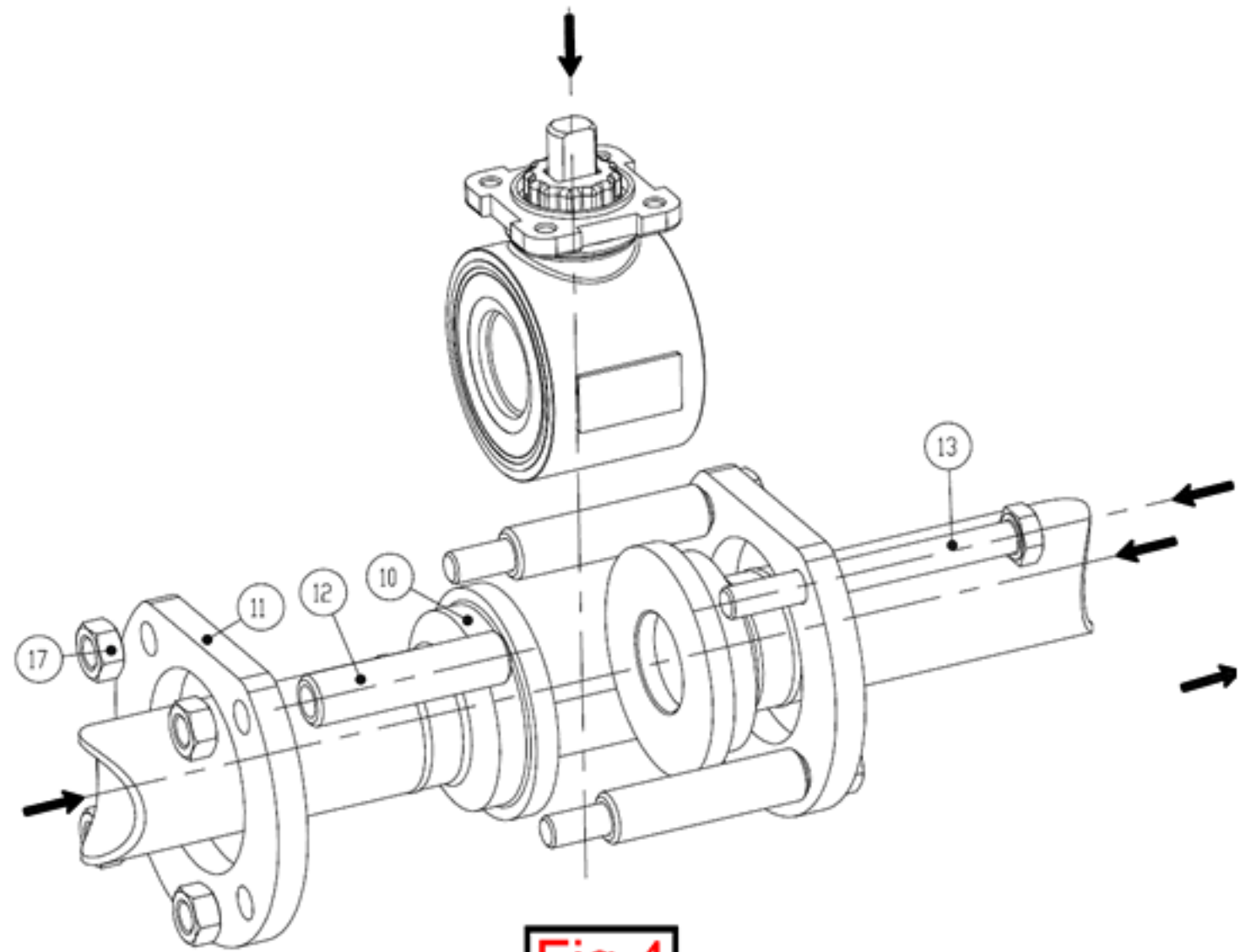

**Fig 3**



### Valve assembly body DN 10 to 50 (Fig 4)

|           |   |    |    |    |    |    |    |    |    |
|-----------|---|----|----|----|----|----|----|----|----|
| Size      | N | 8  | 12 | 15 | 20 | 25 | 32 | 40 | 50 |
|           | V |    | 15 | 20 | 25 | 32 | 40 | 50 | 65 |
| Torque Nm |   | 10 | 10 | 10 | 22 | 22 | 40 | 40 | 60 |

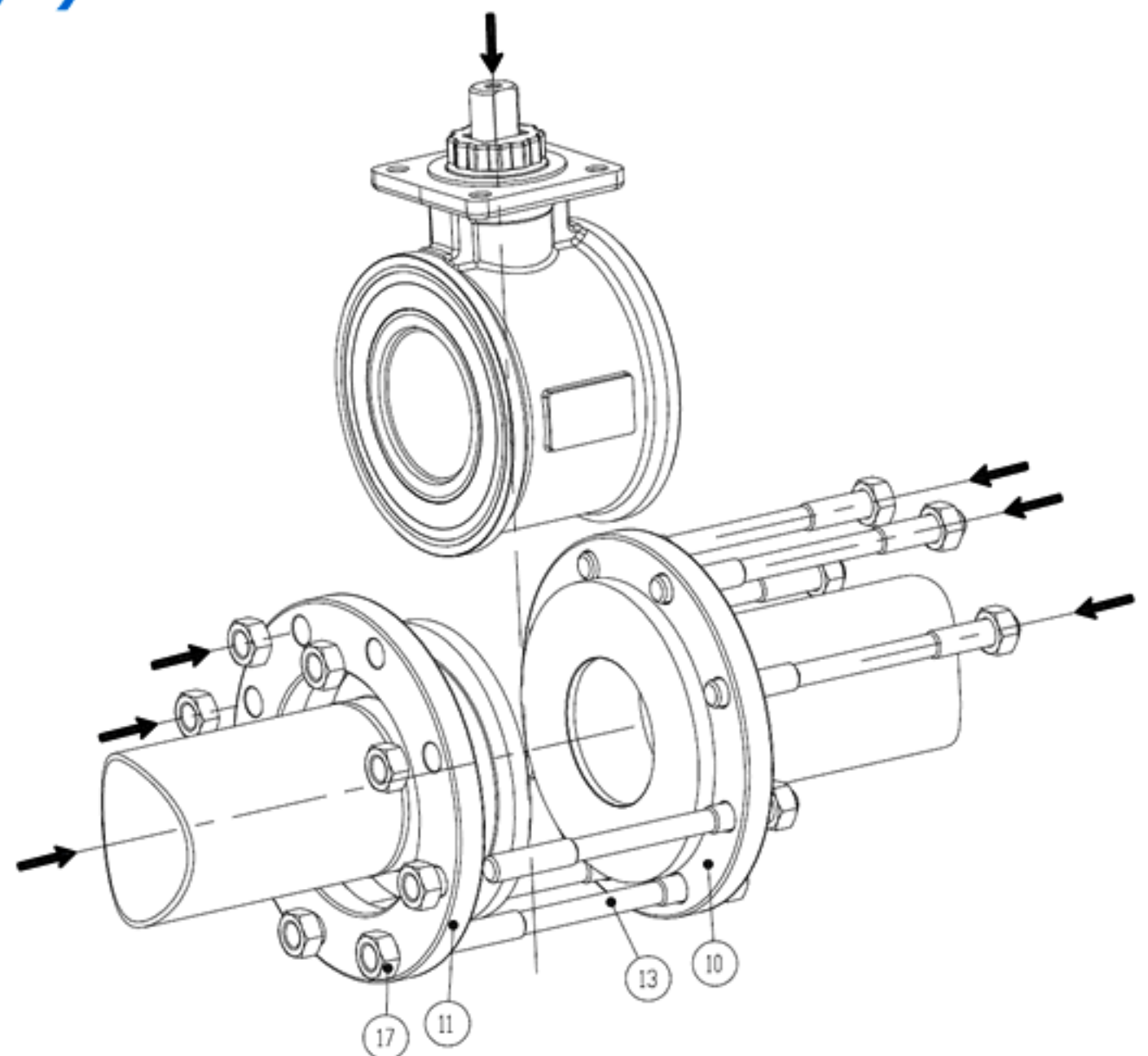

**Fig 4**

1. Insert body flanges (11) into the pipe
2. Weld the ends (10) on pipe
3. Insert screws (13), spacers (12) and nuts in the body flanges (11)  
ONLY insert 3 in order to further allow valve body positioning
4. Insert valve body between ends (ball should be in the open position)
5. Put on the 4th screw (13), spacer (12) and nut (17)
6. Orientate the valve body as required around the pipe and tighten screws (13) and nuts (17) according to the following torque values

### Valve assembly body DN65 to 150 (Fig 5)

|           |   |    |     |     |     |     |
|-----------|---|----|-----|-----|-----|-----|
| Size      | N | 65 | 80  | 100 | 125 | 150 |
|           | V | 80 | 100 | 125 | 150 | 200 |
| Torque Nm |   | 80 | 80  | 80  | 100 | 100 |

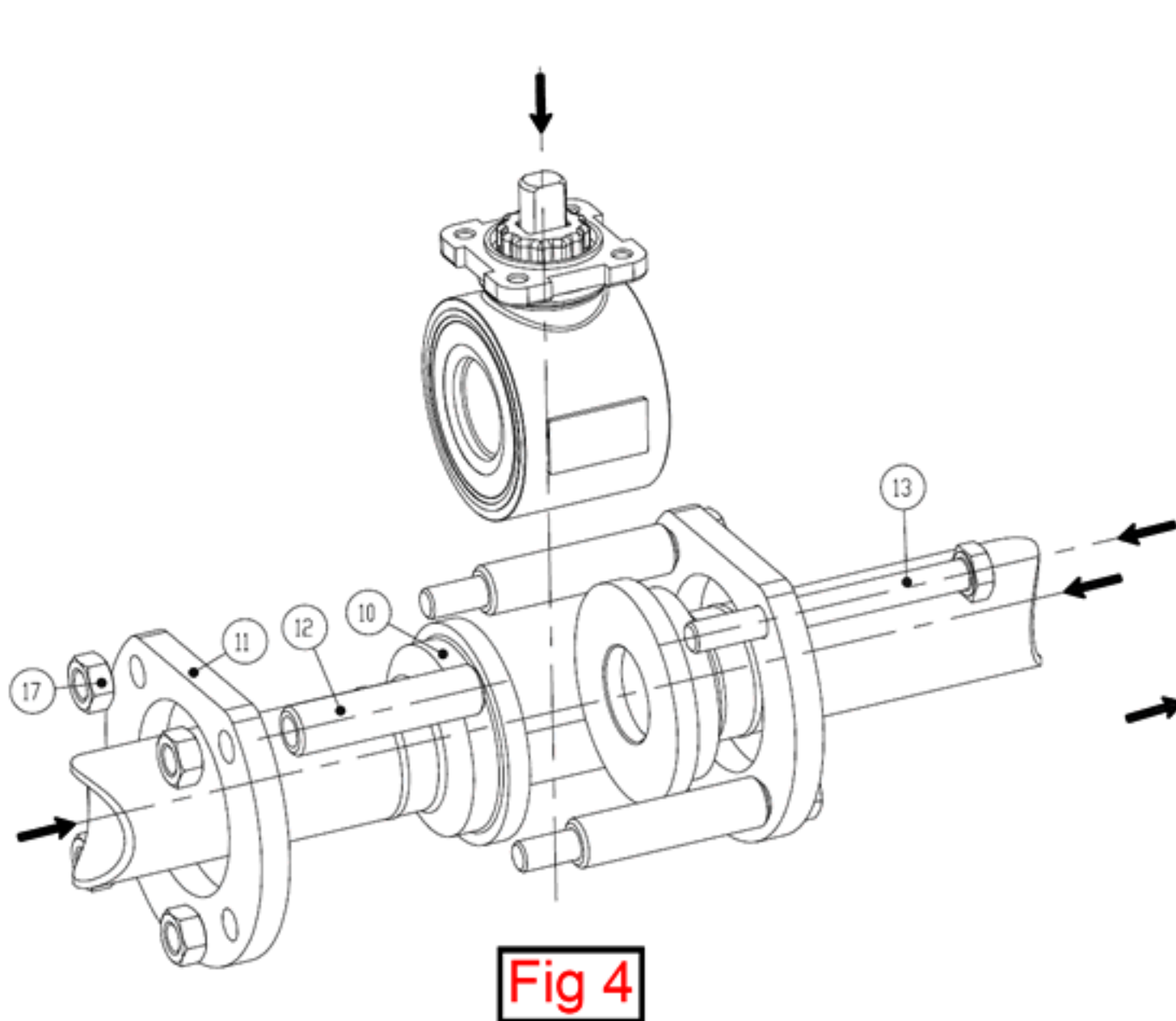

**Fig 5**

1. Insert body flanges (11) into the pipe
2. Weld the ends (10) on pipe
3. Insert screws (13), spacers (12) and nuts in the body flanges (11)  
NOTE to keep some screws apart in order to further allow valve body positioning
4. Insert the valve body between ends (ball should be in the open position)
5. Put on the last screws (13), and nuts (17)
6. Orientate the valve body as required around the pipe and tighten screws (13) and nuts (17) according to the following torque values



### Valve body DN 10 to 50 (Fig 4 & Fig 6)



**Fig 4**

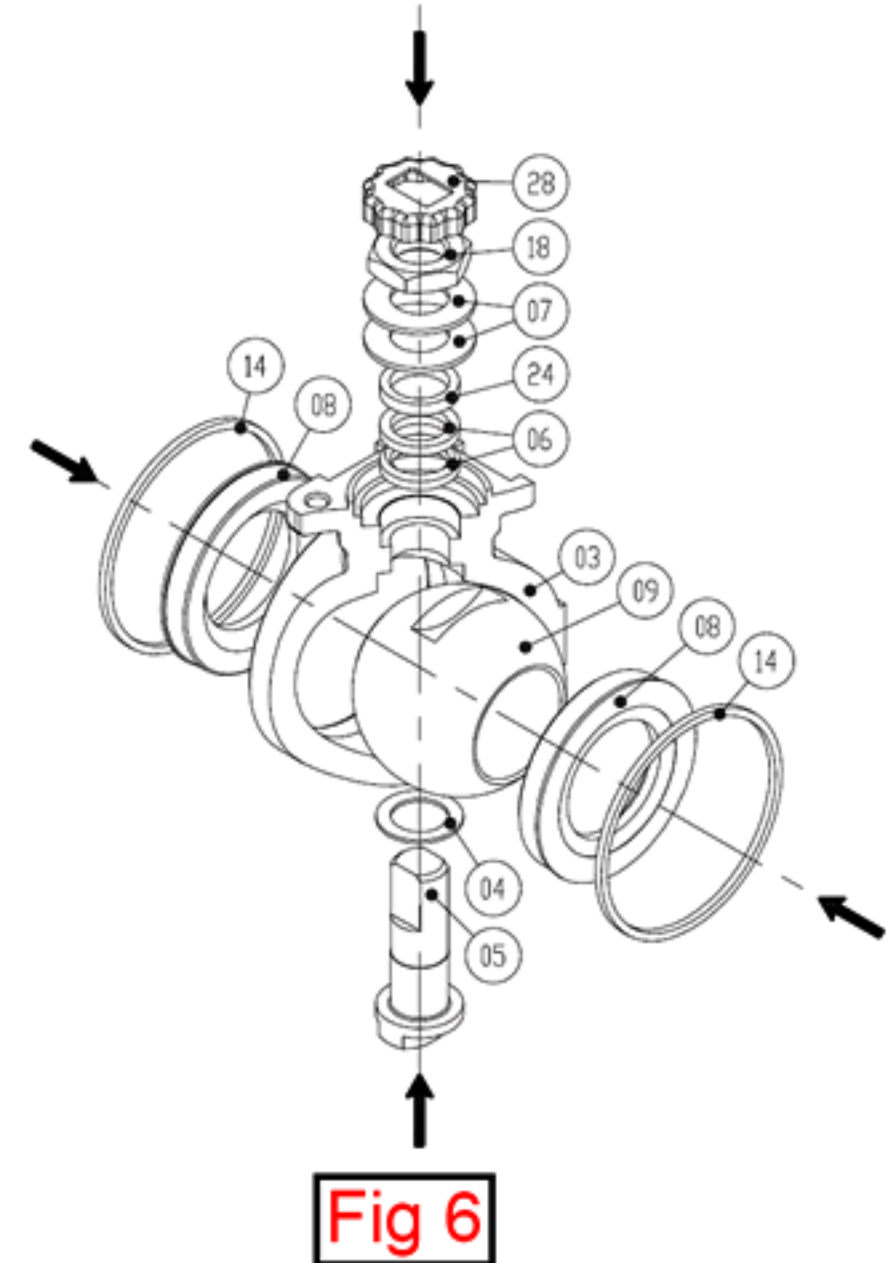

**Fig 6**

#### Seats (08), body seals (14) and ball (09) replacement

1. Unscrew one screw (13) and take it out with the spacer (12) and the nut (17) to allow valve body to be taken out
2. Take out valve body. Ball must be in the open position
3. Operate 90° to allow the ball (09) to be in the close position
4. Push the ball (09) outside of the body. Seats (08) will be pushed as well
5. Take the body seals out (14)
6. Change damaged components
7. Re assemble all components following opposite instructions from 6. to 1.

#### Packing (06), stem seal (04) replacement

1. Unscrew one screw (13) and take it out with the spacer (12) and the nut (17) to allow valve body to be taken out.
2. Take out valve body. Ball must be in the open position.
3. Operate 90° to allow the ball (09) to be in the close position
4. Push the ball (09) outside of the body. Seats (08) will be pushed as well
5. Take out Nut lock (28) and unscrew the nut (18)
6. Take spring washers (07) and gland (24)
7. Push the stem (05) inside the valve – the stem seal keep staying on the stem.
8. Take out stem (05) and replace stem seal (04)
9. Take out packing (06) from valve body and replace with a new one
10. Re assemble following opposite disassembly instructions
11. Screw packing nut (18) following torques values mentioned in here after table.  
Do not forget to refit nut stop (28)

| Size      | N | 8 | 12 | 15 | 20 | 25 | 32 | 40 | 50 |
|-----------|---|---|----|----|----|----|----|----|----|
|           | V |   | 15 | 20 | 25 | 32 | 40 | 50 | 65 |
| Torque Nm |   | 4 | 4  | 4  | 8  | 8  | 12 | 12 | 16 |



### Valve body DN 65 to 150

#### Seats (08), body seals (14), ball (09) replacement (Fig 5 & Fig 7)

1. Unscrew nuts (17) and boltings (13)
2. Take out valve body. Ball must be in open position
3. Operate a 90° turn in order for the ball (09) to be in the closed position
4. Push the ball (09) out of the valve body. Seat supports (20) are also pushed out
5. Take the seats (08) out of the seat supports (20)
6. Take body seals out (14)
7. Replace damage components
8. Re assemble all parts following opposite disassembly instructions  
When re assembling the seats (08) and seat support (20), make sure it is done as per shown on figure 7

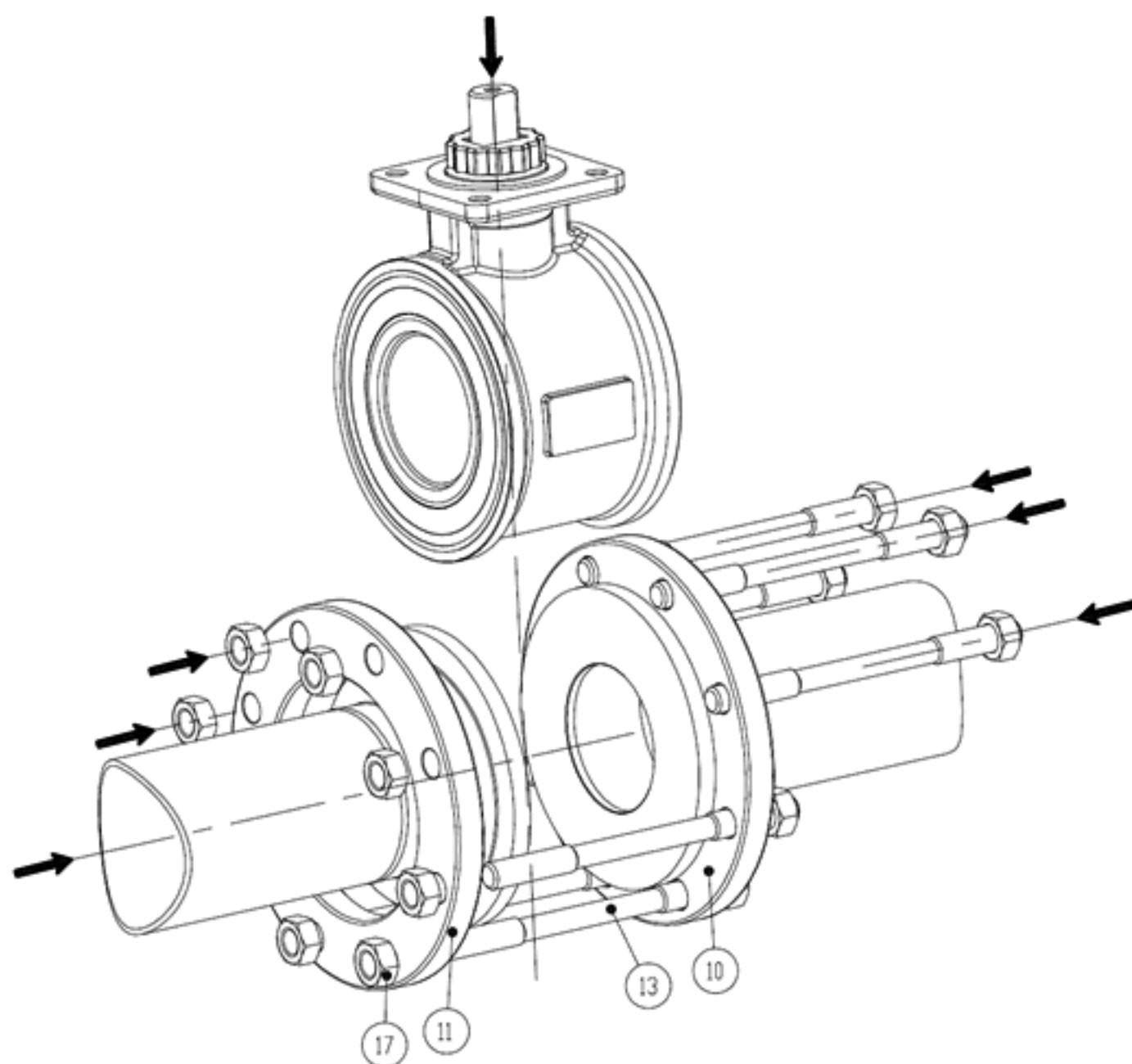

**Fig 5**

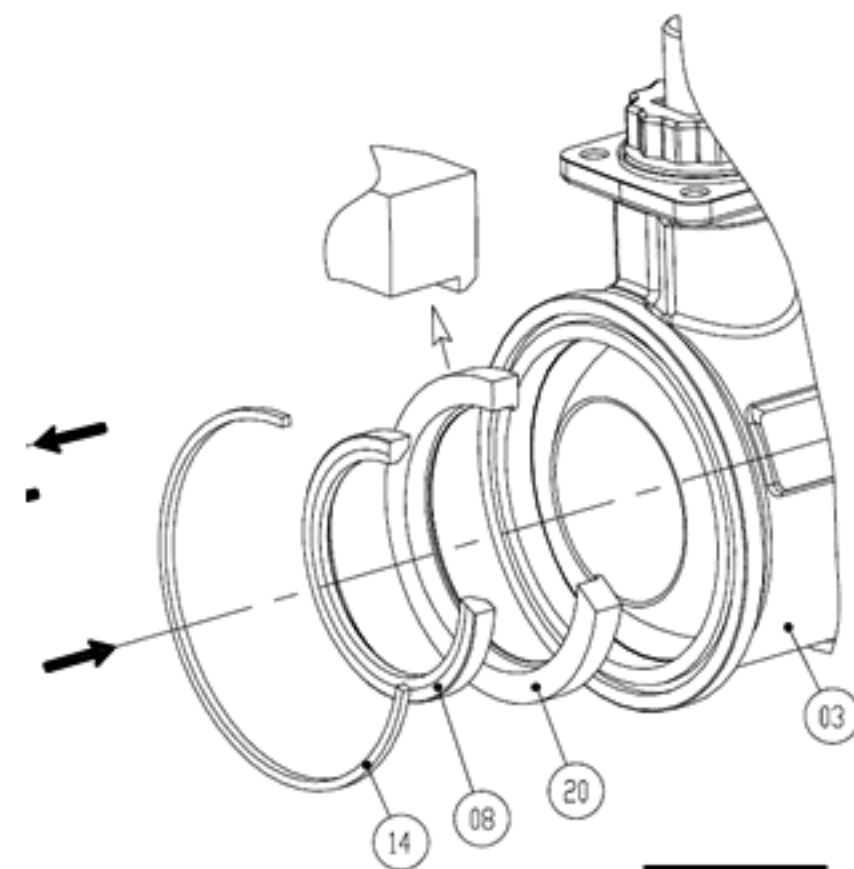

**Fig 7**

#### Packing (06) and stem seal (04) replacement (Fig 5, Fig 7 & Fig 8)

1. Unscrew one screw (13) and take it out with the spacer (12) and the nut (17) to allow valve body to be taken out
2. Take out valve body. Ball must be in the open position
3. Operate 90° to allow the ball (09) to be in the close position
4. Push the ball (09) outside of the body. Seats (08) will be pushed as well
5. Take out Nut lock (28) and unscrew the nut (18)
6. Take spring washers (07) and gland (24)
7. Push the stem (05) inside the valve the stem seal keep staying on the stem
8. Take out stem (05) and replace stem seal (04)
9. Take out packing (06) from valve body and replace with a new one
10. Re assemble following opposite disassembly instructions
11. Screw packing nut (18) following torques values mentioned in here after table. Do not forget to refit nut stop (28)

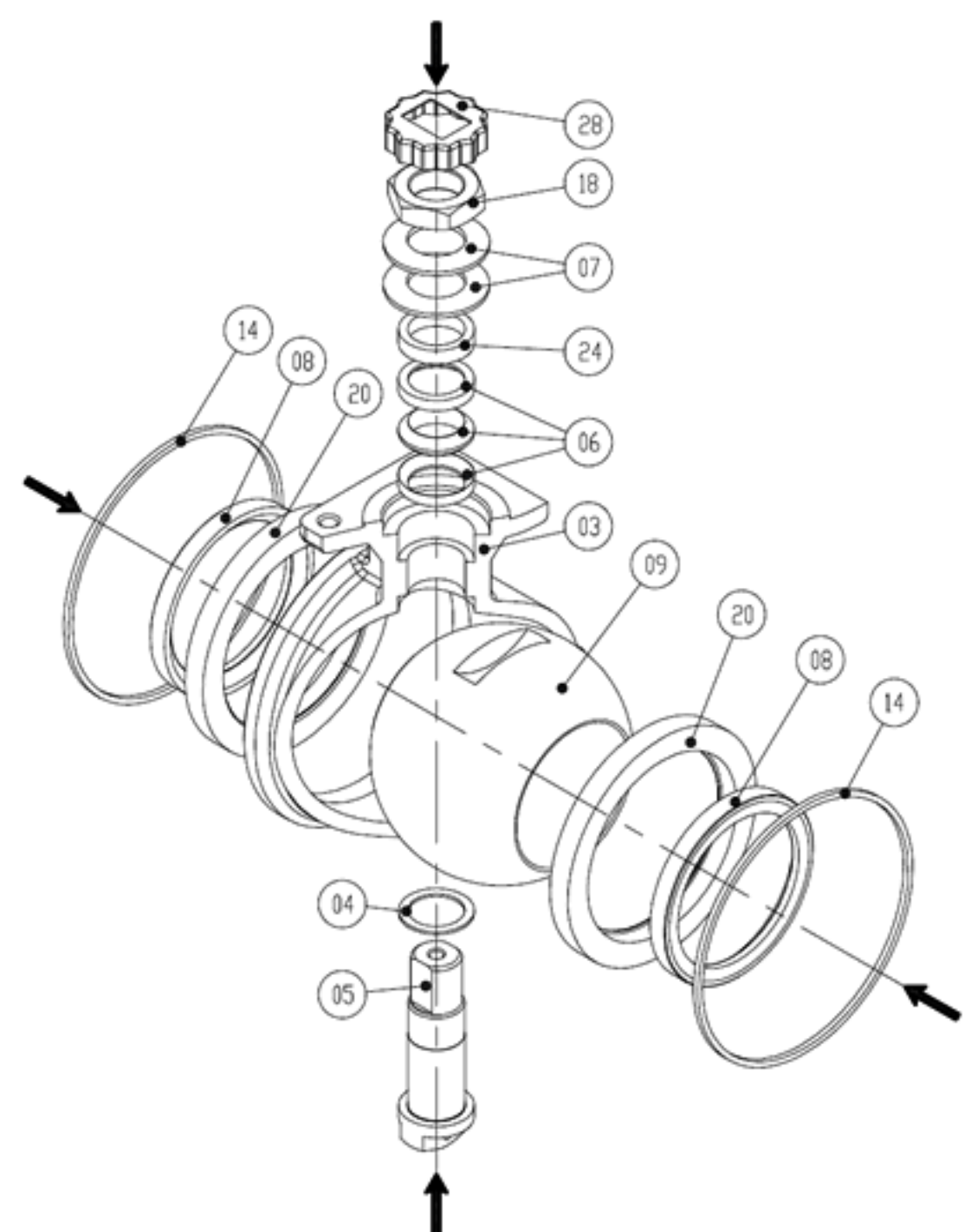

**Fig 8**

| Size      | N | 65 | 80 | 100 | 125 | 150 |
|-----------|---|----|----|-----|-----|-----|
|           | V |    | 80 | 100 | 125 | 150 |
| Torque Nm |   | 35 | 35 | 35  | 50  | 50  |