

# Valve with ball and ring

## Effect of wear in metal seated ball valve

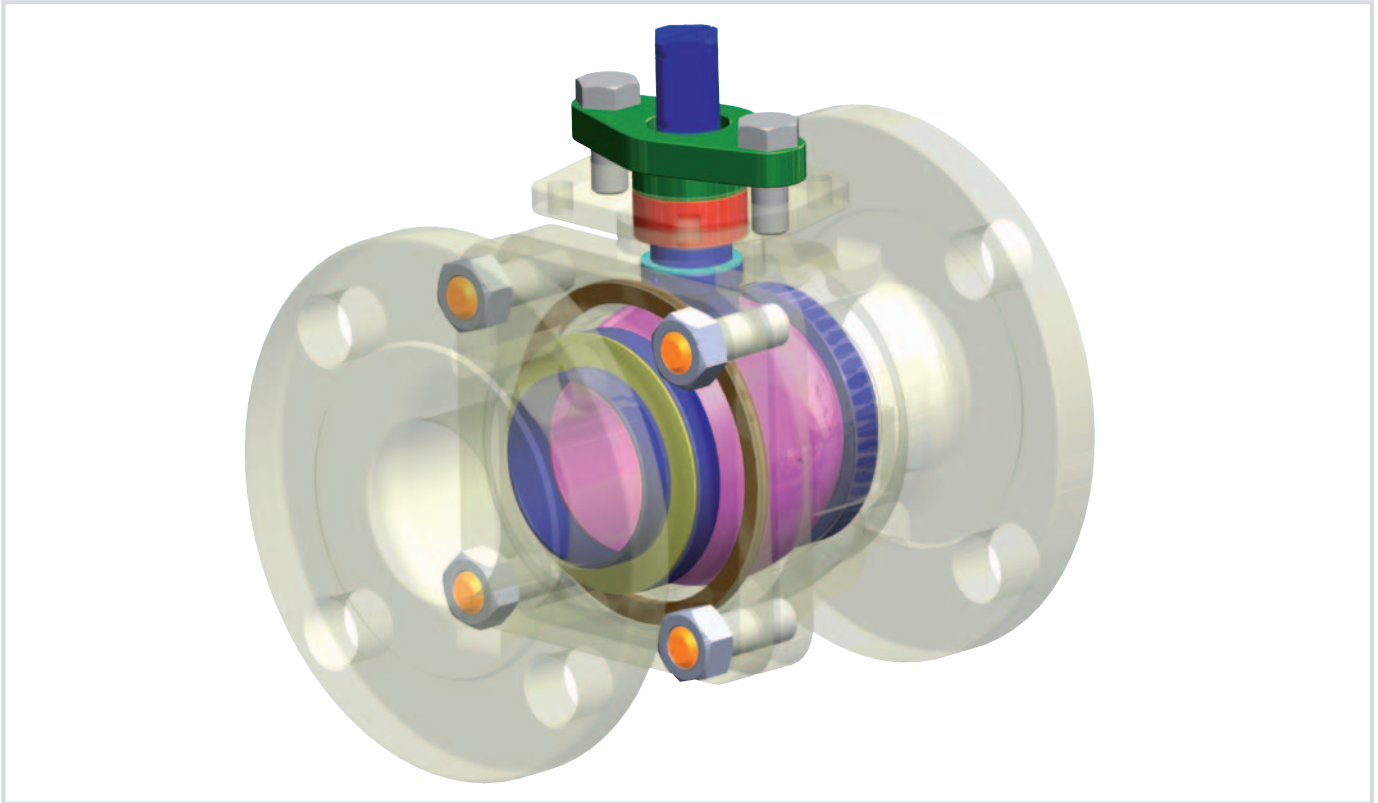

Pictures: JPV Valves

Metal seated valves are used in applications with high requirements, frequently in high-temperature processes with aggressive and abrasive media.

An important criterion for valves at high temperatures is that they must be leak-proof. Metal seated ball valves have often proven to be an all-round solution for these requirements. The areas of application are very wide and they can fulfil the standards for demanding process conditions where they are used.

MURAD SCHONATH

● In addition to the operating temperatures in chemical and petrochemical processes, there are usually requirements on the pressure levels of a valve that are also crucial. Here the construction has a major role to play. Thus for example the „Trunnion“ ball valve design (double mounted ball) or with heating jacket. The heart of a metal seated valve is always the interaction of the ball and sealing system and the sealing system itself. The sealing system with its metallic seat - e.g. stellite - is not only resistant to corrosion, but is also durable and resistant to wear and tear. Leakage continues to be an important requirement criterion for the sealing system of a metal seated valve. It should not be significantly worse than for a standard ball valve. Metal seated ball valves are usually confronted with the issue of wear and tear. The user generally pays a great

deal of attention to this aspect when considering metal seated valves. Wear and tear can be classified in different types according to interactions. These would be: Adhesive wear, abrasion and surface corrosion.

### Adhesion and abrasion

Adhesive wear arises through chemical - mechanical reactions between the ball and the metallic seat. Due to the requirement, that ball and seat must „seal“, these components are paired together in special processing methods, also called „lapping“. The result of this pairing is that valves achieve a high degree of leakproofness, which would not otherwise be possible without this processing method. But even with perfectly processed components, certain wear and tear occurs with time. Abrasion is characterised by mechanical visible attrition between the ball and seat. Abrasion occurs through contact with a correspondingly abrasive product/medium and/or through roughness of the surfaces

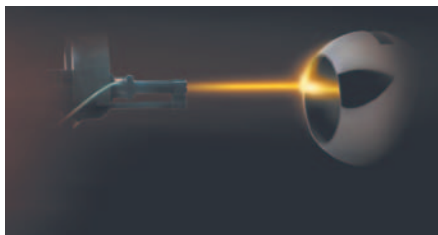

**Surface treatment in HVOF**

of the two components rubbing against each other - ball and seat. Abrasion becomes worse if a product containing solids is also under higher pressure, leading to a higher flow speed in the valve. Challenging applications are to be found for example, in coal production, fly ash transportation in power plants or lime sludge in desalination plants.

**Surface corrosion**

Surface corrosion becomes visible when electrochemical reactions occur between the medium and the materials of the components used and attack their surface. Here a distinction is made between an extensive attack and a locally limited attack on the material surface. The greatest danger for metal seated valves is the locally limited surface corrosion - pitting. Media should not be underestimated that are not really highly aggressive and initially only exist at low concentrations. The relative harmlessness then changes rapidly as soon as the temperature drops below the dew points of the product and condensation occurs. Then a high concentration of aggressive components forms very rapidly,

thereby initiating surface corrosion. Practical examples of this are general exhaust gases in combustion processes - e.g., scrubbers in power plants, chemical applications employing liquid phosphorus and sulphur compounds.

**Spring-loaded construction**

Apart from the criterion required by abrasion, issues such as pressure relief without ball holes and automatic readjustment of the ball seal ring are continually of central importance for safe and durable application. In the case of automatic pressure relief, overpressures enclosed in the space behind the ball are automatically relieved over the sealing system

Here the spring-loaded construction is of central importance.

The manufacturer JDV Valves Ltd. and their partner company Zürcher Technik AG have many years of experience of construction and dealing with such requirements. For more than 30 years, JDV Valves Ltd. have been investing in this technology with their own developments.

In recent

years the emphasis has been placed on surface coating of the inner components with highly resistant processing methods. The well known „HVOF-process“ has been adapted and developed of JDV for specific requirements.

The principle behind this is a combination of plasma and detonation processes for surface coating with cobalt-chromium compounds.

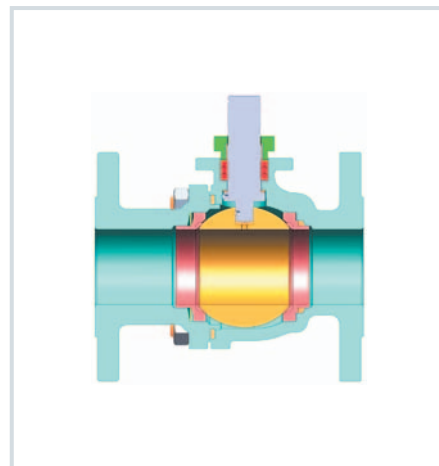

**Basic structure of a metal seated ball valve**

Depending on the requirement, specific hardnesses can be achieved up to 70 HRC.

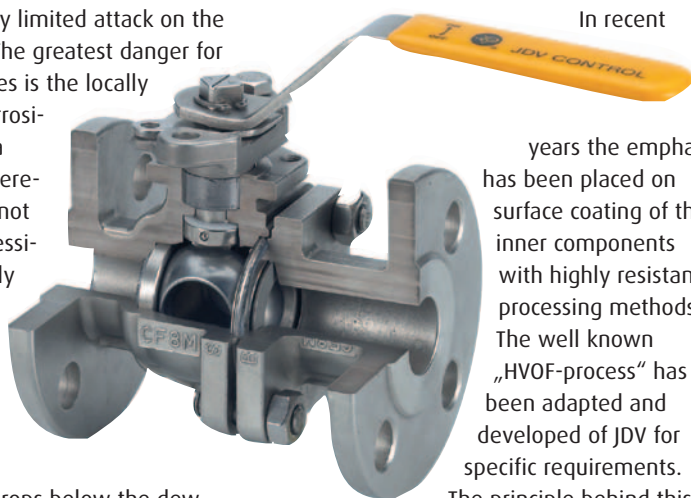

**Automated valve by JDV**

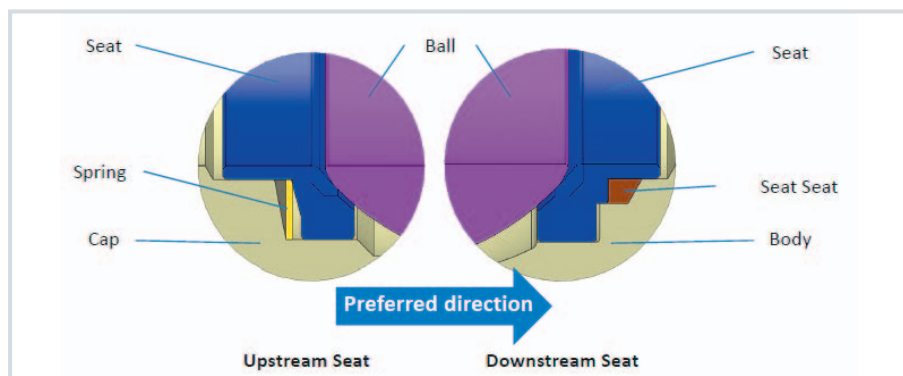

**Automatic readjustment of the ball sealing ring ensures a long, trouble-free operation.**

**Contact:**

Zuercher Technik AG  
 Neumattstrasse 6  
 CH-4450 Sissach  
 Switzerland

Tel.: +41 (0)61 975 10 10  
 Internet: [www.zuercher.com](http://www.zuercher.com)